

Heavydrive[®].com

YOUR TRANSPORT AND LIFTING SPECIALIST

VSG 2000 MH KL 12-6

Operating Instructions



Contents

Foreward	I-I
Technical description Options	1-2
for the VSG 2000 MH KL 12-6	1-4
Basic safety information	2-1
Warning instructions and symbols	2-1
Authorised use	2-1
Organisational measures	2-2
Personnel selection and qualifications	2-3
Safety instructions regarding particular operating stages	2-3
Normal operation	2-3
Special work	2-4
Safety instructions for special types of danger	2-4
Electrical energy	2-4
Oils, greases and other chemical substances	2-4
Commissioning	3-1
Charging the batteries	3-2
The remote control and control elements	3-3, 3-4
Before transporting	3-5
Operation	4-1
Connecting the suction circuits	4-2
Working cycle	4-3
Switching off	4-6
Charging the batteries	4-6

Troubleshooting	5-1
Pumps no longer perform correctly	5-1
Leak check	5-2
Leak check for the entire system	5-2
Leak check without suckers	5-2
Electrical malfunction	5-3
Vacuum pumps do not start when the device is actuated	5-3
Vacuum pumps do not switch off when vacuum of -0.72 bar is reached	5-3
No warning signals	5-3
Rotating cannot be carried out	5-4
Swivelling cannot be carried out	5-4
Maintenance	6-1
The suckers	6-1
The vacuum lines	6-1
Leak check	6-2
The geared motors	6-3
The hydraulic pumps with cylinder	6-3
The vacuum pumps	See appendix
Technical data	7-1
Performance data of the VSG 2000 MH KL 12-6	7-2
Wiring diagram of the VSG 2000 MH KL 12-6	7-3
Spare parts list	8-1
Test report suction pad	See appendix

Foreword

These operating instructions are intended to help you become familiar with the VSG 2000 MH KL 12-6 and to use it as intended.

These operating instructions contain important instructions about operating the VSG 2000 MH KL 12-6 safely, effectively, and economically. Observing them helps to avoid repair costs and down time and to increase the reliability and working life of the VSG 2000 MH KL 12-6.

These operating instructions must be supplemented by additional instructions due to existing national accident prevention regulations.

These operating instructions must always be available at the site of use of the VSG 2000 MH KL 12-6

These operating instructions must be read and observed by every person responsible for doing work on the VSG 2000 MH KL 12-6, for example:

- operation, including equipping, troubleshooting during operation, removal of production waste, care
- maintenance (servicing, inspection, repair) and/or
- transport.

In addition to the operating instructions and binding accident prevention regulations applicable for the country of use and the application case, the recognised technical rules for safe and professional work must also be observed.

If you discover errors when reading these operating instructions, or if you have further comments or suggestions, please contact:

Heavydrive GmbH
Höslerstr. 9
D-86660 Tapfheim

The management appreciates your cooperation.

Technical Description

The VSG 2000 MH KL 12-6 is a combination of four vacuum pumps with power supply (battery or mains, including charger) and a vacuum cross arm with four vacuum circuits working independently from each other. This vacuum cross arm is intended for flexible use on construction sites, at various crane systems, etc., anywhere where no 220 to 240 volt connection is available. Using the VSG 2000 MH KL 12-6, the transported goods can be rotated 360 degrees by two geared motors and also be swivelled

90 degrees hydraulically. The rotation and swivelling movement is operated by remote control with a cable or by radio control. The VSG 2000 MH KL 12-6 is hung on a crane hook and is supplied with energy via the installed batteries. In addition to easy installation on a crane or similar device, the VSG 2000 MH KL 12-6 also offers the safety advantage that in general no vacuum supply hose or voltage supply line is required as is the case with separated devices (cross arm, vacuum pump). In addition, it is also possible to lower transported goods during a power outage with this type of device as long as the vacuum circuit is perfectly sealed, because the vacuum reserve tanks are located on the vacuum cross arm.

In detail, the device consists of a casing frame with suspension eye, the basic frame. This basic frame simultaneously forms the form vacuum reserve tanks and holds the vacuum pumps, the battery charging device, the batteries and the hydraulic pumps. A second rectangular pipe frame is connected to this basic frame first via a swivelling joint and then via a rotating joint. This frame is the carrier frame on which the suckers are mounted. The sucker connections are supplied with a vacuum (suction) or normal compressed air (release) by means of the magnetic valves (suction/release valves) of the four vacuum circuits. You can switch from SUCTION to RELEASE by using a remote control. The suckers can be blocked individually using stop valves. Four inspection vacuum meters provide information on the exact pressure ratios in the vacuum lines to the individual suckers. A voltage display indicates the battery charge level. The charging circuit voltage for the charger is 220-240 volt AC (50/60 Hz). Four vacuum pumps are used to generate the vacuum (one vacuum pump per vacuum circuit). The vacuum pumps work without oil lubrication and are therefore maintenance-free.

In order to avoid draining the batteries unnecessarily, the pump switch has a two-point controller that switches off the vacuum when the pressure reaches -0.72 bar in the vessel, switches the pumps off and switches the pumps back on when the pressure falls below approx. -0.68 vacuum. This avoids premature draining of the batteries due to the pumps being allowed to run unnecessarily. The batteries are maintenance-free and enclosed; it is totally discharge-safe.

Mode of operation

Switch the machine to On using the ON/OFF switch. Then set the magnetic suction/release valves to RELEASE using the remote control. The vacuum cross arm must be positioned on the load to be transported in such a way that all suckers are flat on the smooth clean surface so that the sucker lips can seal completely. Set both suction/release valves to SUCTION with the remote control and wait until the pumps of the vacuum circuits switch off. You can check the vacuum using the vacuum meters 1-4 on the device. If there is a vacuum of -0.72 bar in each vacuum circuit, the load can be transported. To release the suckers from the load, set the suction/release valves to RELEASE.

Options for the VSG 2000 MH KL 12-6

Removable extensions with sucker supports which give greater surface stability when larger panes are transported.

Basic safety information

Warning instructions and symbols

The following terms and symbols are used in the operator's manual for especially important information:

- Note** Special information regarding the economical use of the device
- Caution** Special information regarding requirements and prohibitions for preventing damage.
- Danger** Information or requirements or prohibitions for protecting people or preventing extensive damage.

Authorised use

The VSG 2000 MH KL 12-6 has been constructed in accordance with the state of the art and recognised safety regulations. Nevertheless, its use may result in danger to life and limb of the operator or third parties and impairment of the machine or other property may occur.

The machine may only be used when in technically perfect condition, as authorised. The user must be conscious of safety and risks and act in accordance with the instructions. Failures which can interfere with safety must be eliminated immediately.

The VSG 2000 MH KL 12-6 is exclusively for transporting gas-tight, dry materials with firm, flat surfaces. Other use or use going beyond this, for example transporting gas-permeable materials, film-covered materials, wet materials, or rotating or swivelling large or heavy transported goods is not authorised. The manufacturer/supplier is not liable for the damages resulting from this. The risk is carried by the user.

Use as authorised use also includes complying with the operating instructions and the inspection and maintenance conditions.

Organisational measures

Always keep the operating instructions within reach at the site of use.

In addition to the operating instructions please observe and teach any other generally applicable statutory regulations concerning accident prevention.

Such obligations can also include providing and wearing personal protective equipment.

Please supplement the operating instructions with instructions including supervision and reporting obligations taking into consideration operational corporate circumstances, e.g. relating to work organisation, work processes, personnel used.

The personnel authorised to operate the device must read the operating instructions, particularly the chapter about safety instructions before starting work. It is too late to read the instructions if work has already been started. This applies in particular to personnel who only work on the machine occasionally, e.g. for equipping it and carrying out maintenance work.

Occasional checks should be carried out to ensure that the members of personnel follow the instructions and work in a safety-conscious manner and are aware of risks.

If necessary or if required by regulations, personal protective equipment should be used. Glass should only be transported with the appropriate protective equipment (safety shoes, protective gloves, wrist protectors, helmet etc.) A helmet should be worn at all times when transporting goods above head height.

All safety and danger instructions on the device should be complied with.

All safety and danger instructions on the device should be kept complete and in legible condition.

If there are any safety-related changes to the device or its operation, the device should be stopped immediately and the malfunction should be reported to the relevant office or person.

No changes, attachments or upgrading work that could possibly impair safety should be carried out on the machine without the consent of the supplier. This also applies to the installation and setting of safety equipment and valves as well as to welding on load-bearing parts.

Spare parts must fulfill the technical requirements specified by the manufacturer. This is always guaranteed with original replacement parts.

Vacuum hose lines should be replaced at the specified intervals or at appropriate intervals, even if there are no recognisable safety defects.

Compulsory deadlines or those specified in the instructions for recurring tests / inspections should be complied with

Appropriate workshop equipment is absolutely necessary for performing the maintenance measures.

Personnel selection and qualification

Work on/with the machine may only be performed by reliable personnel. The legal minimum working age should be observed.

Use only trained or instructed personnel; responsibilities among personnel should be clearly established for operation, equipping, maintenance, and repair.

Ensure that only authorised personnel works on the machine.

Specify a person who is responsible for operating the machine and give him/her the opportunity to refuse to comply with the safety instructions of third parties.

Personnel being trained or instructed, or who are taking part in a general training programme, may only work on the machine when under the constant supervision of an experienced person who is familiar with this situation.

Work on the electrical equipment of the machine may only be performed by an electrician or by trained personnel under the direction and supervision of an electrician in accordance with the rules of electrical engineering.

Safety instructions on particular operating phases

Normal operation

Avoid all unsafe work practices.

Before starting work, become familiar with the working environment at the site of use. The working environment includes impediments in the work and traffic area, the load bearing capacity of the floor, and cordoning off the worksite from public traffic areas.

Take measures to ensure that the machine is only operated when safe and functional.

Check the machine for externally recognisable damages and flaws at least once per shift. Report any changes that occur (including those to the operating behaviour) immediately to the responsible office/person. If necessary, stop the machine immediately and secure it!

During malfunctions, the machine should be stopped immediately and secured. Malfunctions should be corrected immediately.

The switching on and off procedures should be complied with, and the inspection displays should correspond to the operating instructions.

Always stop work if it becomes dark or if visibility is poor!

Special work

The setting, maintenance, inspection activities and deadlines, including information on replacement of parts and modules stipulated in these operating instructions must be observed. These activities may only be performed by authorised specialists.

Only perform maintenance and repair work when the machine is positioned on flat ground with sufficient bearing capacity and is secured so that it cannot roll away or collapse.

Clean machines, particularly connections and screw connections at the beginning of maintenance/repair work. Do not use aggressive cleaning agents! Use lint-free cloths for cleaning.

Never clean the machine with water or steam jet (high-pressure cleaner).

After cleaning, inspect all vacuum lines for leaks, loosened connections, abrasion and damage. Repair any flaws immediately!

Always tighten screw connections loosened during maintenance and repair work.

Safety instructions for special types of danger

Electrical power

Use only original fuses with the specified current strengths. Switch off the machine immediately during malfunctions to the electrical energy supply.

Work on electrical equipment or operating materials may only be performed by an electrician or by trained personnel under the direction and supervision of an electrician in accordance with the rules and regulations of electrical engineering.

Machine and system parts on which inspection, maintenance, or repair work must be performed, must be switched free of current if required. First check the switched off parts to ensure that they are free of voltage, then ground and short-circuit them, and insulate neighbouring live parts.

The electrical equipment of the machine must be checked regularly. Flaws such as loose connections and melted cables must be repaired immediately.

Oils, greases, and other chemical substances

Observe the safety regulations applicable for the product when using oils, greases, and other chemical substances!

Commissioning

Note

- Do not store the VSG 2000 MH KL 12-6 in a damp or very cold (frost) environment. Otherwise there is no guarantee that the installed pump will function properly.
- Rotation and swivelling can only be carried out when the pumps in the four vacuum circuits are switched off.
- Swivelling can only be carried out when the VSG 2000 MH KL 12-6 is hanging from a crane hook or similar, i.e. the hydraulic pump is in a vertical position.

Caution

- Always ensure that the suckers are not placed on sharp edges because this could damage the sucker lips. This would lead to leaks in the suction circuit, impairing the functioning of the device.
- Never place the machine with mounted suckers with the rubber surfaces of the suckers on sandy or similar ground. This could damage the sealing lips of the suckers. This would lead to leaks in the suction circuit, impairing the functioning of the device. Or the grains of sand or similar substances could be pressed into the rubber surfaces, leading to damage to the upper surface of the transported goods.

Danger

- Do not allow heavy rain to fall on the VSG 2000 MH KL 12-6.
- Do not place the VSG 2000 MH KL 12-6 in water.
- Do not convey loads over persons or machines. Cordon off the area under hanging transported goods with wide clearance.

Charging the batteries

Check the VSG 2000 MH KL 12-6 for any externally recognisable damages or flaws.

Compare the connection on the power supply network and check the voltage, current and mechanical connection (plug connection) with the necessary data for the vacuum pumps. If they do not correspond, the machine may not be operated.

Connect the VSG 2000 MH KL 12-6 to the supply network using an extension cable.

The charging procedure can be checked in voltage display after pressing the test button.

After the charging procedure is completed, a value of 100% must be visible in the voltage display when Test button is pushed.

The batteries are charged after a maximum of 12 hours.

Remove the extension cable from the supply network.

This completes the charging procedure.

Note

After the transporting work is completed, switch the device off with the switch in order not to drain the batteries unnecessarily.

The remote controls with cable

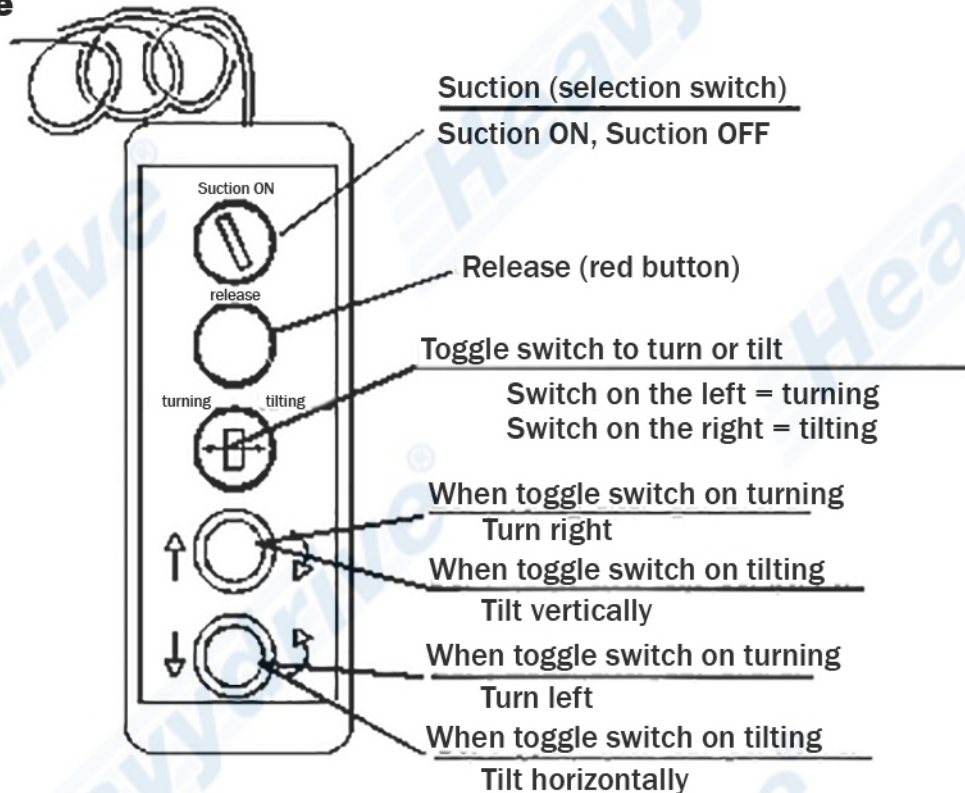

with radio control

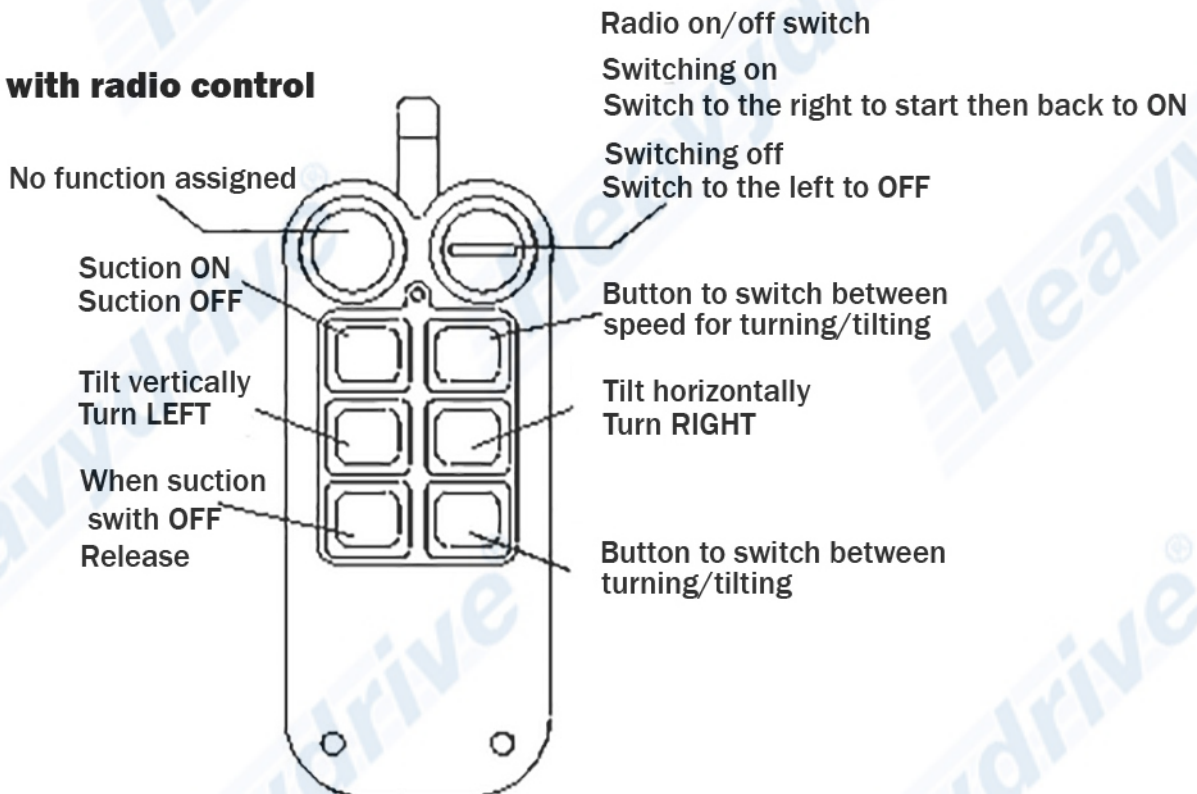

VSG 12 KL

Remote manual

- a** Main switch (ON - OFF)
- b** *Plugin for remote-control (Wire or radio-remote)
- c** Remote-receiver
- d** Control light (Main switch on/off)
- e** Control light (Lights when remote-control is connected)
- f** Control light (Light goes out, if Suction system 1 has enough negative pressure)
- g** Control light (Light goes out, if Suction system 2 has enough negative pressure)
- h** Battery control (Works with switch **k**)
- i** Manometer (suction system 1)
- j** Manometer (suction system 2)
- k** Battery control switch
- l** Battery charging control

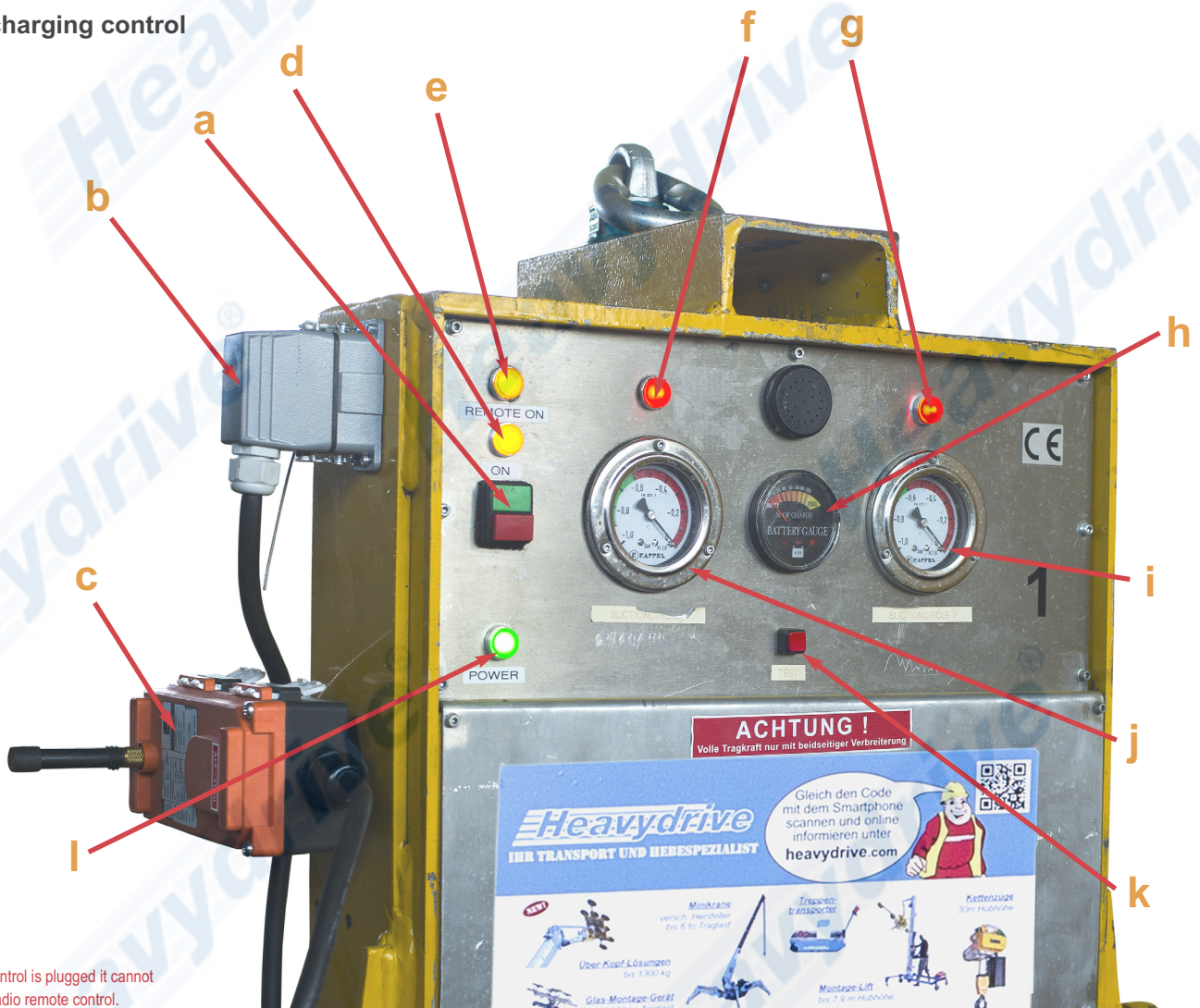

* If the wire remote control is plugged it cannot be switched to radio remote control.

- a** Main switch (ON - OFF)
- b** Emergency stop switch (press to stop, turn right to release)
- c** Control light (lights when remote control is connected)
- d** Button (suction system 1 – suction/release)
- e** Button tilt down/turn right
- f** Button changes between tilt and turn for the buttons **e** and **h**
- g** Button (suction system 2 – suction/release)
- h** Button tilt up/turn left
- i** Safety/two hand button for hold/release (press these button AND **d+g** for suction/release)
- j** Battery slot

Radio remote control

1. Connect remote control:

Turn main switch (**a**) complete to the right (like starting a car), it turns automatically back to „ON“

Disconnect remote control:

Turn main switch (**a**) left

2. Turn or tilt

Use button (**f**) to change between tilting and turning, then use the buttons (**e**) and (**h**) to move



Wire control

- a + b** Suction / release button. Press for suction, pull for release
- c** changing between rotation (turn) and tilting
- d + e** Tilting and rotation, able to change with button **c**

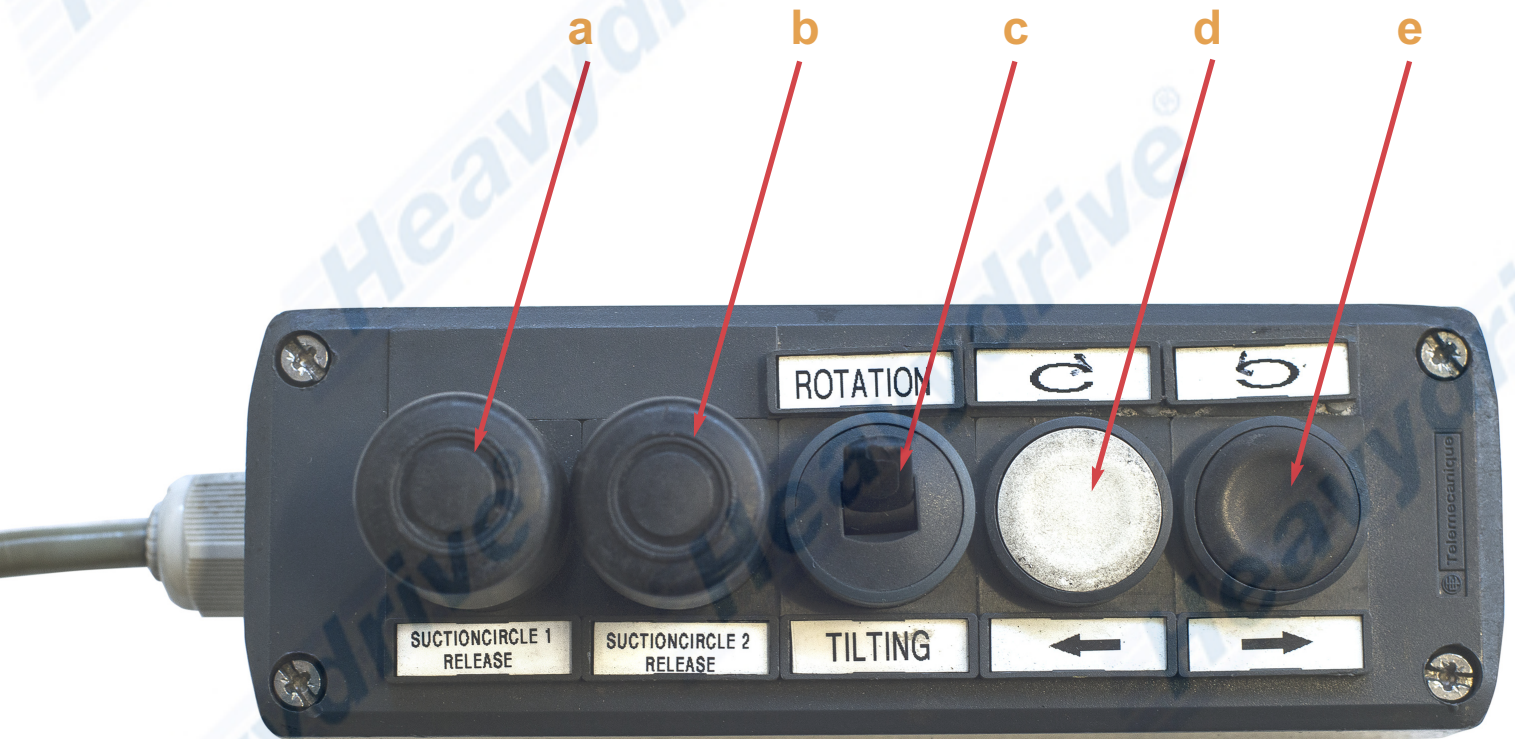

The control elements

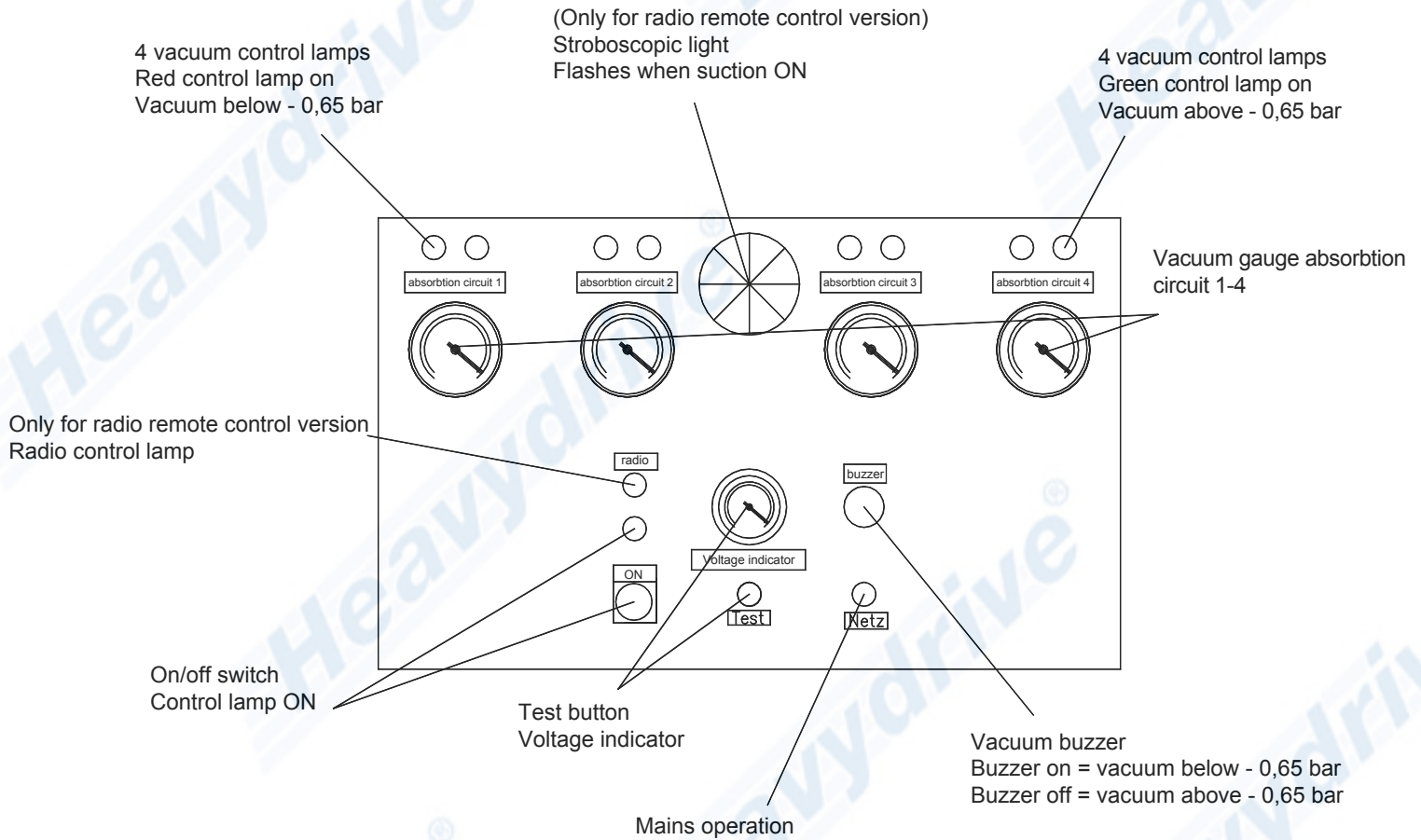

Before transporting

Check the VSG 2000 MH KL 12-6 for any externally recognisable damage or flaws.

Hang the VSG 2000 MH KL 12-6 from the suspension eye on a crane hook or similar device.

Detach the vacuum lines to the suckers using the vacuum couplings.

Then switch the device to On using the on/off switch and switch the rotary switch suction to On.

The pumps must start up if the vacuum is insufficient. The four control indicator lights vacuum red and the signal tone signalise insufficient vacuum. The existing vacuum in the vacuum circuits can be checked on the four vacuum meters. After a short time, a vacuum of at least -0.65 bar should have built up in each vacuum circuit, the indicator lights turn red and the signal tone stops and the indicator lights light up green.

The vacuum pumps switch off when -0.72 bar vacuum is reached. This should be the case after a short time. The indicators of the vacuum meters must then be in the green area.

In order to check the vacuum, the rotary switch suction must be set to Off.

Then switch the device switch off and wait ten minutes. During this time the indicators of the inspection vacuum meters may not move.

Even if only one indicator changes, the device is leaking and may no longer be used until the error has been corrected.

Connect the vacuum lines to the suckers via the vacuum couplings.

In order to check the tightness of the hose lines and the individual suckers, either a larger plate or several smaller plates of a gas-impermeable material must be present. These plates are held onto the individual suckers and then sucked on. A vacuum of at least -0.65 bar should build up immediately in each vacuum circuit. When this happens, the machine switch must be switched off. Read the achieved vacuum from the inspection vacuum meter and compare it with a reading taken about 15 minutes later.

If there is no discrepancy, the device is leak-tight and safe to operate. If a discrepancy of more than 5% occurs, the VSG 2000 MH KL 12-6 must be checked to find the leak.

(see Troubleshooting).

Commissioning is complete once the machine switch has been switched back on.

Caution

The VSG 2000 MH KL 12-6 must only be commissioned with **four** functional vacuum circuits.

Operation

Note

- Do not store the VSG 2000 MH KL 12-6 unit in a damp or very cold (frost) environment. Otherwise there is no guarantee that the installed pumps will function properly.
- Rotation and swivelling can only be carried out when the pumps in the four vacuum circuits are switched off.
- Swivelling can only be carried out when the VSG 2000 MH KL 12-6 is hanging from a crane hook or similar, i.e. the hydraulic pump is in a vertical position.

Caution

- Always ensure that the suckers are not placed on sharp edges because this could damage the sucker lips. This would lead to leaks in the suction circuit, impairing the functioning of the device.
- Never place the machine with mounted suckers with the rubber surfaces of the suckers on sandy or similar ground. This could damage the sealing lips of the suckers. This would lead to leaks in the suction circuit, impairing the functioning of the device. Or the grains of sand or similar substances could be pressed into the rubber surfaces, leading to damage to the upper surface of the transported goods.

Danger

- Do not allow heavy rain to fall on the VSG 2000 MH KL 12-6
- Do not place the VSG 2000 MH KL 12-6 in water.
- Do not convey loads over persons or machines. Cordon off the area under hanging transported goods with wide clearance.

Connecting the suction circuits

The same number of suction pads distributed must be the same as the number of suction circuits to ensure that the load is distributed evenly in case one of the suction circuits fails.

Example of connection

With 24 suction pads 6 pcs./ vacuum circuit.

With 16 suction pads 4 pcs. / vacuum circuit

Caution

-Blue hose lines	vacuum circuit 1	vacuum couplings blue
-black hose lines	vacuum circuit 2	vacuum couplings black
-yellow hose lines	vacuum circuit 3	vacuum couplings yellow
-red hose lines	vacuum circuit 4	vacuum couplings red

Caution

The VSG 2000 MH KL 12-6 must only be commissioned with **four** functional vacuum circuits.

Working Cycle

Before the transporting work can start, the quantity of suction pads must be determined on the basis of the weight of the goods to be transported so that if one suction circuit fails, the quantity of remaining suction pads is sufficient for transporting the load.

Arrange the suckers according to the size of the transported goods. Possibly move the suckers in the carrier frame.

Use the remote control to determine the position of the carrier frame via the geared motor and the hydraulic cylinders, into which the transported goods are to be sucked on (see page 3-3 Remote control).

Position the VSG 2000 MH KL 12-6 on the respective goods to be transported

Note

- Rotation and/or swivelling can only be carried out if the pumps in both vacuum circuits are switched off.
- Swivelling can only be carried out if the VSG 2000 MH KL 12-6 is hanging on a crane hook or similar, i.e. the hydraulic pump is in the vertical position.

Caution

The surface must be absolutely free of dust, rust particles, water and similar
Clean the surface with glass-cleaner, detergent or similar.

If it is necessary to clean the goods to be transported, use a fat solvent that evaporates without any residue, such as Nitro or brake-cleaner.

Caution

- An uneven (A) load distribution is not permitted during rotation!
- Ensure an even (B) load distribution during rotation.

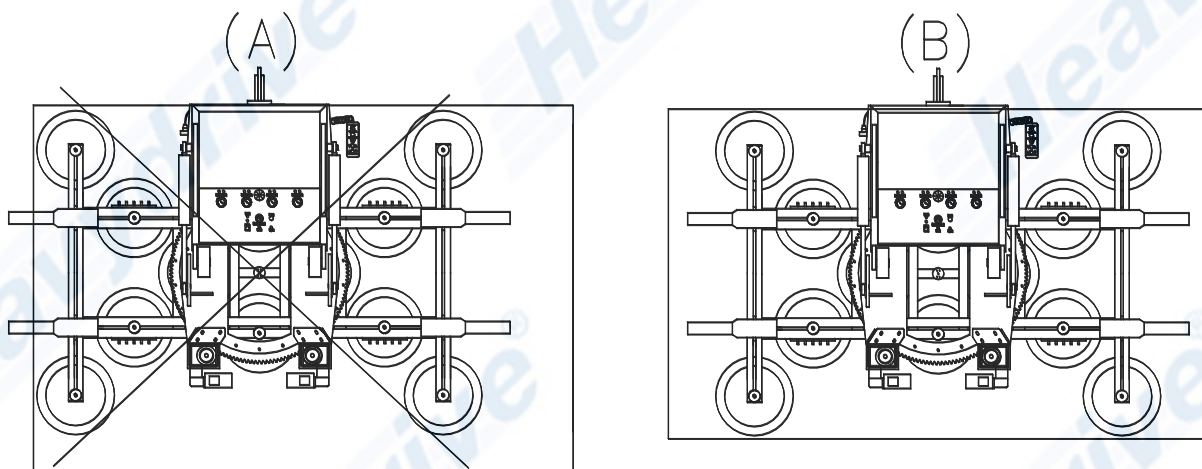

Caution

- Top-heavy (C) load distribution is not permitted during swivelling.
- (D) load distribution near the ground is not permitted during swivelling.
- Ensure bottom-heavy (E) load distribution during swivelling

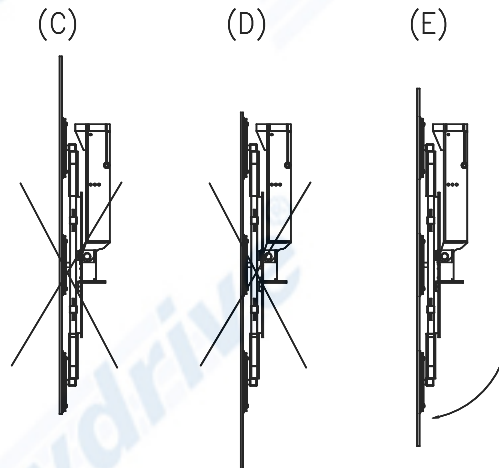

Check that all suckers on the surface are clean and have full contact and, if necessary, press on or align a sucker that is not making contact until it is in the correct position. If this is not done, a vacuum cannot build up and the VSG 2000 MH KL 12-6 can therefore not lift the material. Set the suction/release valves to the suction position using the remote control.

Caution

- The stop valves on the vacuum reserve tanks must be opened.

Check the vacuum achieved using the inspection vacuum meters. The vacuum indicator lights and the signal tone indicate insufficient vacuum. The transport procedure can take place with the pumps switched off as soon as there is -0.72 bar vacuum in each of the four vacuum circuits.

Danger

- Do not convey loads over persons or machines.
- If the vacuum sinks below -0.65 bar in one of the vacuum circuits during transport work, a signal tone sounds. In this case, try to set down the load as soon as possible so that it does not fall down

The transported goods are guided from the side, which means that the operator stands as far as possible from the transported goods in order to guide them.

To rotate or swivel the transported goods with the remote control see page 3-3, the transported goods must always be positioned according to the drawing (B) or (E). It must also be ensured that the swivelling motion can be performed without danger and that no damage occurs to the transported goods.

The transported goods are rotated and swivelled from the side, which means that the operator stands outside the area in which the transported goods are rotated or swivelled.

If you want to release the transported goods, the suction switch must be set to OFF and the release switch must be activated.

If the inspection vacuum meters indicate 0, the procedure is completed and the cross arm is released from the transported goods. It can occur that the VSG 2000 MH KL 12-6 remains stuck to the transported goods only to then release them, which can lead to a small shock that shakes the transported goods. Therefore hold on tightly to the transported goods during the release procedure.

Note

- If the batteries are drained, you can also use the VSG 2000 MH KL 12-6 in network mode.

You only have to ensure that the cable to the network supply line is run appropriately.

Charging the batteries

Check the VSG 2000 MH KL 12-6 for any externally recognisable damage or flaws.

Compare the connection on the power supply network with regard to voltage, current, and mechanical connection (plug connection) with the necessary data for the vacuum pumps: If they do not correspond, the machine may not be operated.

Connect the VSG 2000 MH KL 12-6 to the mains power supply at the plug using an extension cable.

The charging procedure can be checked in voltage display after the Test button has been pressed.

After the charging procedure is completed, a value of 100% must be visible in the voltage display when Test button is pushed.

The batteries is loaded after a maximum of 12 hours.

Remove the extension cable from the mains power supply

This completes the charging.

Note

After completing transport work, switch the machine off using the switch in order not to drain the batteries unnecessarily.

Troubleshooting

Pumps no longer perform correctly

The machine no longer reaches -0.72 bar vacuum.

Please check whether all suckers contact the transported goods cleanly; align them if necessary.

Check the suckers and hose lines for possible damage and replace them if necessary.

Check hose clamps for firm fit and tighten them if necessary.

Leak check

Leak check for the entire system

You can perform a leak check of the four independently functioning vacuum circuits to find the leak as follows.

First of all, you should check the entire vacuum circuits with all suckers and the hose lines to the four vacuum circuits.

To do so, it is necessary to set all suckers on a gas-impermeable, flat material (for example, a metal or glass sheet) that can be sucked up. Then switch the device to On using the On/Off switch and set the rotary switch suction to On. When the maximum achievable vacuum, as a rule approx. -0.72 bar in each vacuum circuit is achieved, set the rotary switch suction to Off and switch off the device.

Read the achieved vacuum from the vacuum meters and record the value in writing. The indicators of the vacuum meters should only change slightly within the next fifteen minutes, not more than 5%. If the result of this test is positive, the vacuum lifting device is tight and you can work with it without risk. If a leak is detected even in only one vacuum circuit, the leak must be corrected immediately or the porous material replaced.

Leak check without suckers

If the result of the test of the entire circuit is negative, the next step is to check the vacuum reserve tanks with the supply lines to the connections of the individual suckers.

Connect the vacuum lines to the suckers via the vacuum couplings.

Then switch the device to On using the on/off switch and switch the rotary switch suction to On and continue with the leak test as described above. If this test runs positively, it is tight from the vessel areas to the individual stop valves and the error must be in the supply lines of the individual suckers or at the suckers themselves. Connect one sucker after the other and test each one in the same way. To do this, the sucker must be sealed with a gas-impermeable material. This procedure determines the defective area exactly and the error can be corrected quickly by replacement.

Electrical malfunction

Vacuum pumps do not start when the device switch is actuated

- Vacuum supply sufficient. Device running correctly.
- Batteries empty? Press button Test to check voltage display. Run machine in mains operation or charge battery.
- Check safety cutouts
- Vacuum monitor for switching point P2 defective? Replace
- Circuit board defect? Have circuit board checked by an expert.
- Relay fuse in switch cabinet R7 and R8 defective? Replace

Mains operation not possible

- Main control light is not on? Check cutout S1
- Have mains supply checked by an expert

Vacuum pumps do not switch off when -0.72 bar vacuum is reached.

- Vacuum monitor P2 defect. Replace.
- Circuit board defect? Have circuit board checked by an expert.

No warning signals

Vacuum above -0.65 bar? Device OK.
Vacuum monitor P1 defective? Replace.
Signal buzzer defective? Replace.

Electrical malfunction

Rotation movement cannot be carried out

- Vacuum pumps are active

Swivelling movement cannot be carried out

- Vacuum pumps are active

Maintenance

Note

Please note that the trades association requires an annual inspection of vacuum lifting devices by a specialist, in accordance with the accident prevent regulations (VbG 9a-prEN 13155:1998). If you do not have a suitable staff member, we offer a maintenance contract for our vacuum lifting devices which includes annual maintenance including testing and certification. Please contact us for details.

Heavydrive LLC
Peachtree Rd. NE, Suite1500
Atlanta, GA, 30326
Phone: +1 470 407 4352

The suckers

The suckers must be cleaned occasionally with a clean cloth. Please do not use a solvent (such as gasoline or similar substances). Never treat the suckers with talc, lubricants, or smoothing agents, as this impairs the adhesion of the suckers, causing the transported goods to slip from them.

The vacuum lines

The hoses must be inspected occasionally for visible cracks, etc. Replace defective hoses immediately!

Leak check

A leak test of the four independently functioning vacuum circuits must be performed at least once a week. You should check the entire vacuum circuit with all suckers and the hose lines.

To do this, it is necessary to set all suckers of the vacuum cross bar on a gas-impermeable, flat material (for example, a metal or glass sheet) that can be sucked up. Switch the device to On using the On/Off switch and set the rotary switch suction to On. When the maximum achievable vacuum, as a rule approx. -0.72 bar in each vacuum circuit, has been achieved, set the rotary switch suction to Off and switch off the device.

Read the vacuum obtained from the vacuum meters and record the value in writing. The indicator of the vacuum meters should only change slightly within the next 15 minutes, not more than 5%. If the result of this test is positive, the vacuum lifting device is tight, and you can work with it without risk.

If the test of only one of the vacuum circuits is negative, you can repair the leak and seal it or replace the leaking material, as described in the Troubleshooting chapter. The leak must be corrected immediately or the porous material replaced.

Caution

Always check the operational safety of the pumps and the other elements before starting work / commissioning.

Caution

The VSG 2000 MH KL 12-6 must only be commissioned with **four** functional vacuum circuits.

The Geared motors

- Maintenance free

The Hydraulic pumps with cylinder

- Maintenance free

Technical data

Manufacturer: Designation:	Heavydrive LLC Vacuum suction system (battery operated) VSG 2000 MH KL 12-6
Type:	
Serial number:	592
Year of manufacture:	2016
Operating instructions:	Art. no: VSG 2000 MH KL 12-6
manufacturer/authorised representative	Heavydrive LLC Peachtree Rd. NE, Suite 1500 Atlanta, GA, 30326 Telefon: +49 9070 96 8 96 90-0 Telefax: +49 9070 96 8 96 90-9

Performance data for VSG 2000 MH KL 12-6

Maximum size of the plate material to be transported

With extensions 1 (short)

Height:	approx. 9230 mm
Width:	approx. 450 mm

With extensions 2 (long)

Height:	approx. 12230 mm
Width:	approx. 450 mm

Frame size

Height:	4300 mm
Width:	450 mm
Depth:	400 mm

Temperature range

Operating temperature

Storage temperature	-1 to +35°C (ambient)
	-5 to +50°C (ambient)

Dead weight

1000 kg

Vacuum storage tank

<u>Hose connection</u>	0.75 litre vacuum circuit 6 mm
------------------------	-----------------------------------

Any information regarding the carrying capacity refers to even surface load. Furthermore, all suckers must have solid suction contact with the goods to be transported.

VSG 2000 MH KL 12-6, supplied with suckers type: T-15

Number of suckers: 28

Carrying capacity vertical: 2000 kg Carrying capacity horizontal: 2000 kg

Suckers type T- 15

Diameter:	320 mm
Carrying capacity on smooth, clean, dry Surface with 60% vacuum	
Vertical:	150 kg
Horizontal:	150 kg
Vacuum connection:	6 mm

Four vacuum pumps

Supply voltage:	24V, DC
Nominal current:	approx. 4A/pump

Two batteries

Supply voltage:	12V, DC
Nominal capacity:	approx. 50 Ah

Mains operation

Supply voltage:	115 / 230V, AC
Mains frequency:	50/60 Hz

Rotation drive

Geared motor	24V 240W
--------------	----------

Swivel drive

Hydraulic cylinder with pump	24V 150W
------------------------------	----------

Wiring diagram VSG 2000 MH KL 12-6

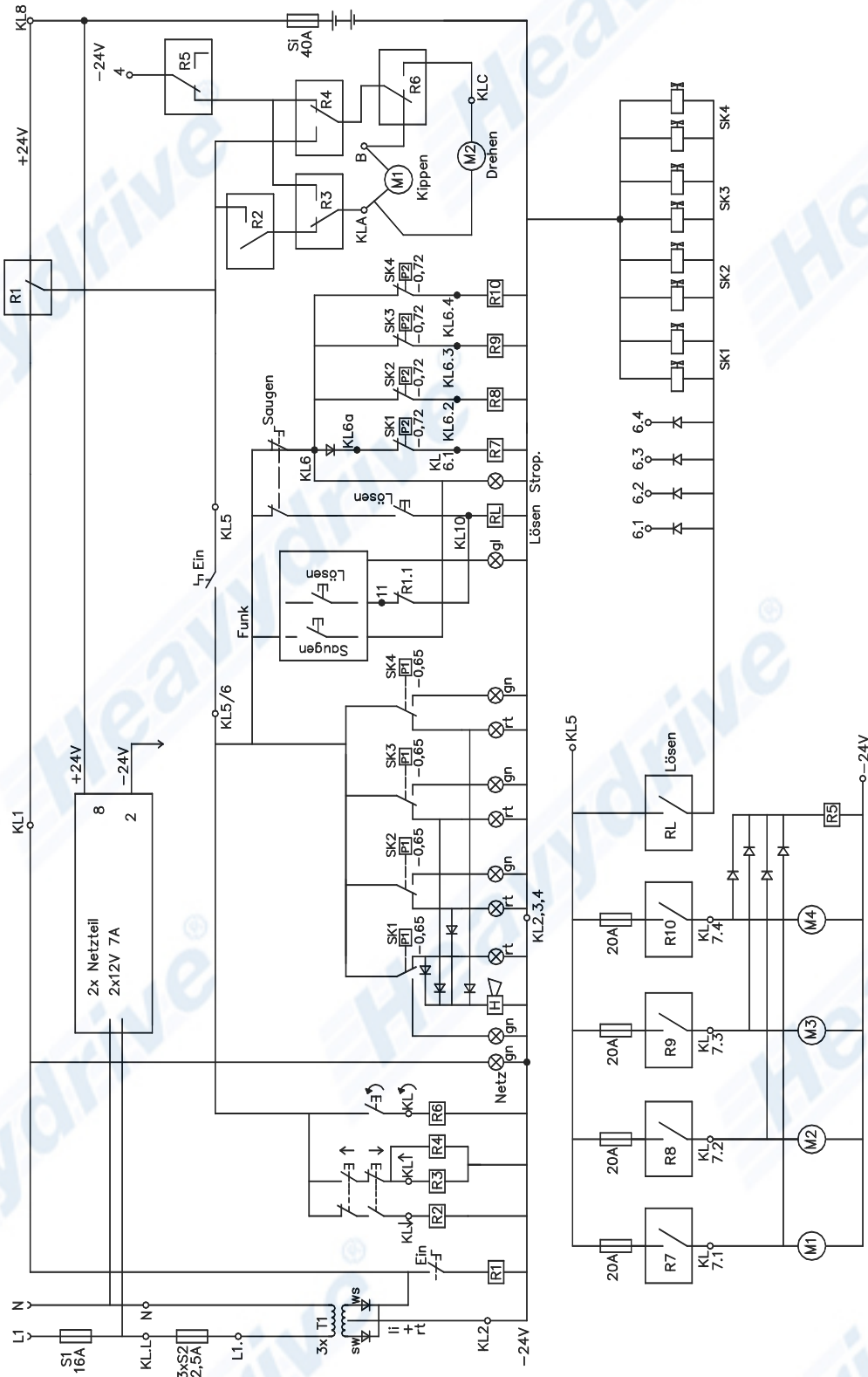

Spare parts list for VSG 2000 MH KL 12-6

Position	Order no.	Quantity	Designation
1	M30 / 4.7 t	1	Suspension eye/articulated suspension
2	LX98206	4	Vacuum meter 63mm ¼"
3		--	Suction pad T- 15
4		1	Remote control
5	905708	1	Schuco connector
6		1	Test button, locking, ON
7	118.068.14	1	Buzzer (horn) 24V DC
8	706124	1	Test button
9	64590	1	Charge indicator 24 V DC
10	726052	4	LED indicator lamp 24V red (alarm)
11		4	LED indicator lamp 24V green
12	726079	1	LED indicator lamp 24V ultra green (network)
13		2	LED indicator lamp 24V yellow
14		4	vacuum pump Dynaflo
15		2	Battery 12V DC 50 Ah
16	SMC EVT 325	8	
17	Mader	8	3/2 way valve 1/8" 24V DC
18	MWL008,0035	12	mini ball valve ¼" ia/shut-off valve
19	6.256.540	8	Vacuum control, type 625
20	6.256.540	8	Vacuum control, type 625
21	Distributor tube rail	4	Distributor tube rail in pairs
22	Rectus 18	16	¼" vacuum S.S.
23	859829	3	Magn. core transf. RKT 300VA / 230V /2x 12V
24		2	Geared motors
25		2	Hydraulic cylinder
26		2	Hydraulic aggregate 1 pcs. 2.5 t
27		2	Charger 12V 7A